

KBC2100 Bridge Crane

SN 006

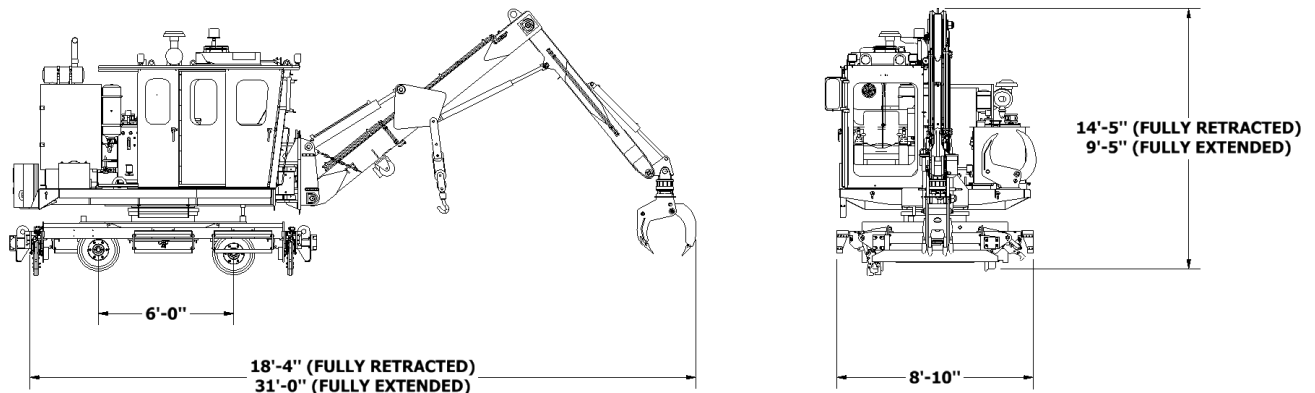

Knox Kershaw's KBC2100 Tie Handling Bridge Crane is capable of handling 1200 lbs. at a radius of 24 ft. from track centerline. The 4000 lb. capacity winch easily handles caps and stringers within a radius of 10 ft. from track centerline. Center locking rail dogs clamp the machine to the rails for working over the side. The upper deck and tie grapple are capable of 360° rotation. The boom can also swing 60° in either direction and the grapple can tilt. Boom and grapple design provides the ability to replace ties, caps, and stringers quickly, with minimal manpower.

Upper Deck and Mainframe: Heavy duty all welded reinforced construction to withstand loading and provide long life. Minimal tail swing to reduce the possibility of fouling the adjacent track (on 11'-6" centers).

Cab: Fully enclosed cab includes ergonomic seat with joystick controls for all boom operations. Air conditioner with heater and pressurizer are standard equipment. Equipped with travel lights, work lights, brake lights, strobe light, horn, and fire extinguisher.

Propel System: 3 15/16" diameter alloy steel axles. Both axles are driven with hydraulic motors. An optional series/parallel propel system is available for increased tractive effort and speed.

Wheel and Brakes: 20" cast steel wheels. Service brakes are air applied, spring released; and parking brakes are spring applied, air released on all wheels.

Engine Assembly: Cummins QSB4.5, 110 hp, Tier 3, 24V electrical system

Hydraulic System: Pressure compensated pump (direct coupled to engine) provides power for propel and all boom/grapple operations. A gear pump (coupled to pressure compensated pump) is provided for continuous cooling and polishing of the hydraulic oil.

Capacities: Fuel: 80 gal. (303 L), Hydraulic Tank: 58 gal (220 L)

Weight: 22,000 lbs. (9980 kg)

Optional Equipment: Series/Parallel propel, Extended cab, Hydraulic drive A/C, Insulated wheels, Basket grapple, Two tie grapple, Toolbox, Lexan windows, Rear window wiper, Bumper kit, Brush cutter attachments, Manual or electric replenishment pump, Test stations.



11211 Trackwork Street
Montgomery, AL 36117
334-387-5669; 334-387-4554 fax
www.knoxkershaw.com