

KKA1050 Kribber Adzer

S/N ≥ 064

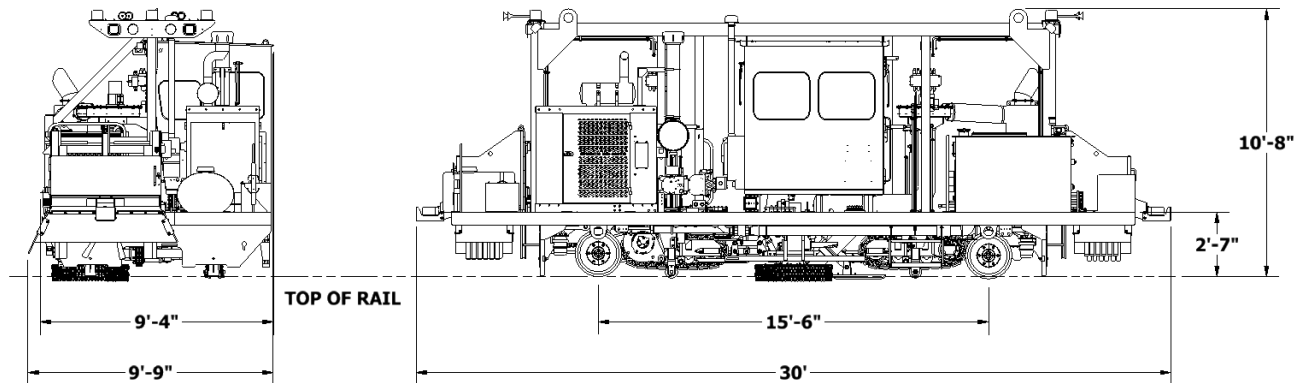

Knox Kershaw's KKA1050 Kribber Adzer is designed for clearing out the cribs (at the tie plate area) and adzing the ties in a continuous operation. This takes place when one rail has been removed for replacement by a rail gang.

Engine Assembly: Cummins QSB6.7, 240 hp, Tier 3. Electronic engine warning system and external oil drain.

Cab: Air conditioned, sound insulated, comfortable operator's seat with mechanical suspension and seat belt, electric wipers, air horn, travel and work lights, safety glass windows, side entry door that opens to inboard access platform. Engine monitor and all gauges integrated into one high-resolution color display.

Kribber: Side shifting mechanism for lateral adjustment. 25" of vertical adjustment. Sweeping width of 24". Single hydraulic motor drive per kribber directly coupled to kribber shaft. Each kribber uses both round, solid elements and knocker elements. Motors are plumbed to run at high or low speed (operator controlled).

Adzer: Vertical deployment system for swift, accurate height adjustment of adzer head. Adzer head cutting depth is controlled using hydraulically controlled skids which allow adzer head to float and maintain a consistent cut. 21" diameter, 6-bit adzer head comes standard. Work speed is automatically adjusted dependent upon adzer load.

Brakes: Air applied brakes with cobra shoes. One shoe per wheel. Spring applied parking brakes on all four wheels.

Dust Collector: A cyclone dust collection system is mounted on the corner of the mainframe. This particular style of system is a positive pressure cyclone system that uses a material handling fan to vacuum up debris and then blow the debris into the cyclone. Inside the cyclone the debris is separated and will fall from the bottom opening of the cyclone. The majority of the smoke and air will exit the cyclone through the top mounted exhaust stack.

Capacities: Fuel Tank: 150 gal (568 L), Hydraulic Tank: 145 gal (549 L)

Weight: 32,000 lbs. (14,515 kg)

Note: Knox Kershaw Inc. reserves the right to make design improvements that may obsolete these specifications. Illustrations may show optional equipment that will not be included on all machines.



Knox Kershaw Inc.

11211 Track work Street
Montgomery, AL 36117
334-387-5669; 334-387-4554 fax
www.knoxkershaw.com